

A

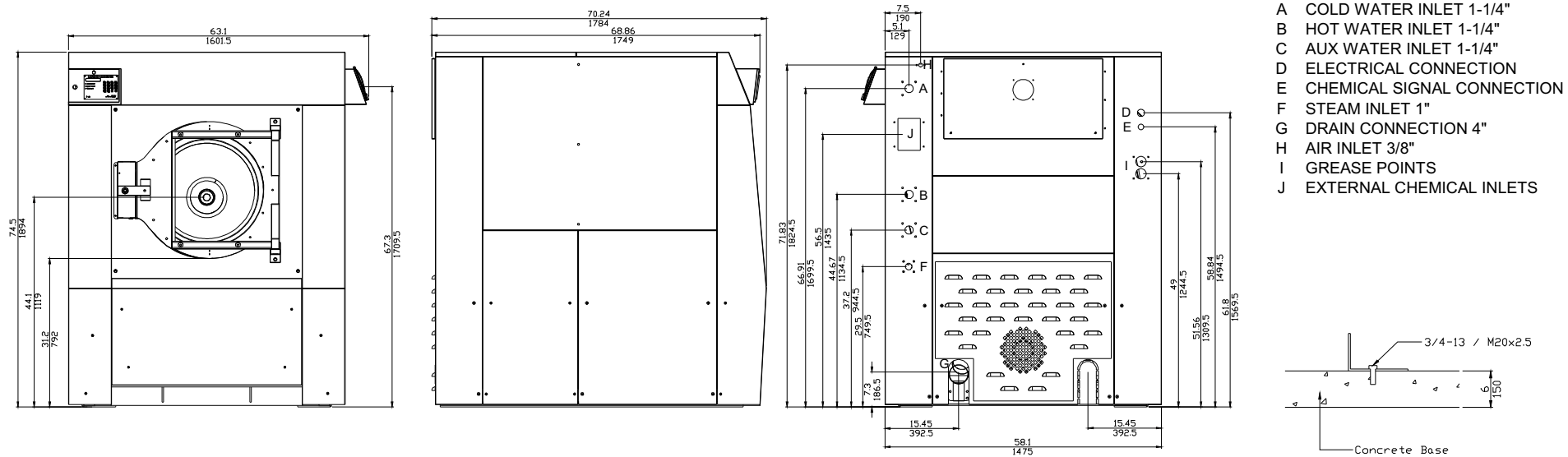

- A COLD WATER INLET 1-1/4"
- B HOT WATER INLET 1-1/4"
- C AUX WATER INLET 1-1/4"
- D ELECTRICAL CONNECTION
- E CHEMICAL SIGNAL CONNECTION
- F STEAM INLET 1"
- G DRAIN CONNECTION 4"
- H AIR INLET 3/8"
- I GREASE POINTS
- J EXTERNAL CHEMICAL INLETS

**Electrical Requirements**

Voltage	Phase	System Wire	Wire Size	Amps	Breaker
208-240VAC, 50/60Hz, 3PH	3	3 + GND	6	58	60
380-460VAC, 50/60Hz, 3PH	3	3 + GND	12	29	30

**Drain Requirements**

Connection Size		Discharge Rate		Min Sewer Line	
inches	mm	gal/min	liters/min	inches	mm
4	102	150	560	5	127

**Water Requirements**

Water						Flow Rate (@45PSI/3Bar)		Minimum Supply Line Size		Max Operating Pressure	
Connection Size		Line Pressure		Max Temp		gal/min	liter/min	US	Metric	US	Metric
US	Metric	PSI	Bar	F	C						
1-1/4"	DN 32	30-75	2-5	200	93	37	140	1-1/2	DN 38	125 PSI	8 Bar

**Steam Requirements**

Steam				Minimum Supply Line Size		Max Operating Pressure	
Connection Size		Line Pressure		US	Metric	US	Metric
US	Metric	PSI	Bar				
1"	DN 25	30-75	2-5	1"	DN 19	100 PSI	6 Bar

**Dynamic Load Specifications**

Static floor load		Static pressure		Total Dynamic Load		Dynamic pressure		Dynamic Frequency
kN	lbs	kN/m2	lbs/ft2	kN	lbs	kN/m2	lbs/ft2	Hz
24.53	5514	8.6	179	11.1	2505	3.9	81	11.67

**Shipping Data**

Type	lbs	kg	cu ft	cu m
Domestic	4697	2135	222	6.3
Export	4763	2165	222	6.3

**Compressed Air**

Connection Size		Consumption		Pressure	
US	Metric	US	Metric	US	Metric
3/8" NPT		0.5 CFM	0.01 CMM	80-100 PSI	5.5-7 BAR

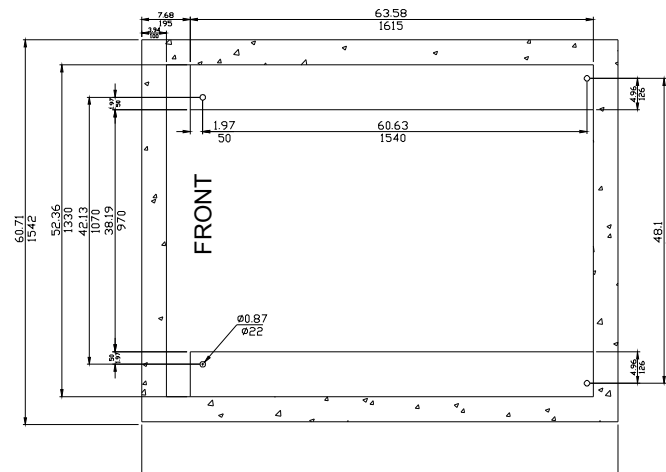

REV A2	BY AFA	DATE 10-23-2015	REV. DESCRIPTION Added compressed air req
DRAWN BY A. Adcock		DATE 9-30-2013	 Panama City, FL Phone: 850-249-2222 Fax: 850-249-2226 www.bandctech.com
CHECKED BY C. Oswald		DATE 9-30-2013	
DESCRIPTION General Technical Specifications <b>SP-195</b>			
DATE 9-30-2013	FILE NAME SP-195GenSpec.cdr	SHEET 1 OF 1	