

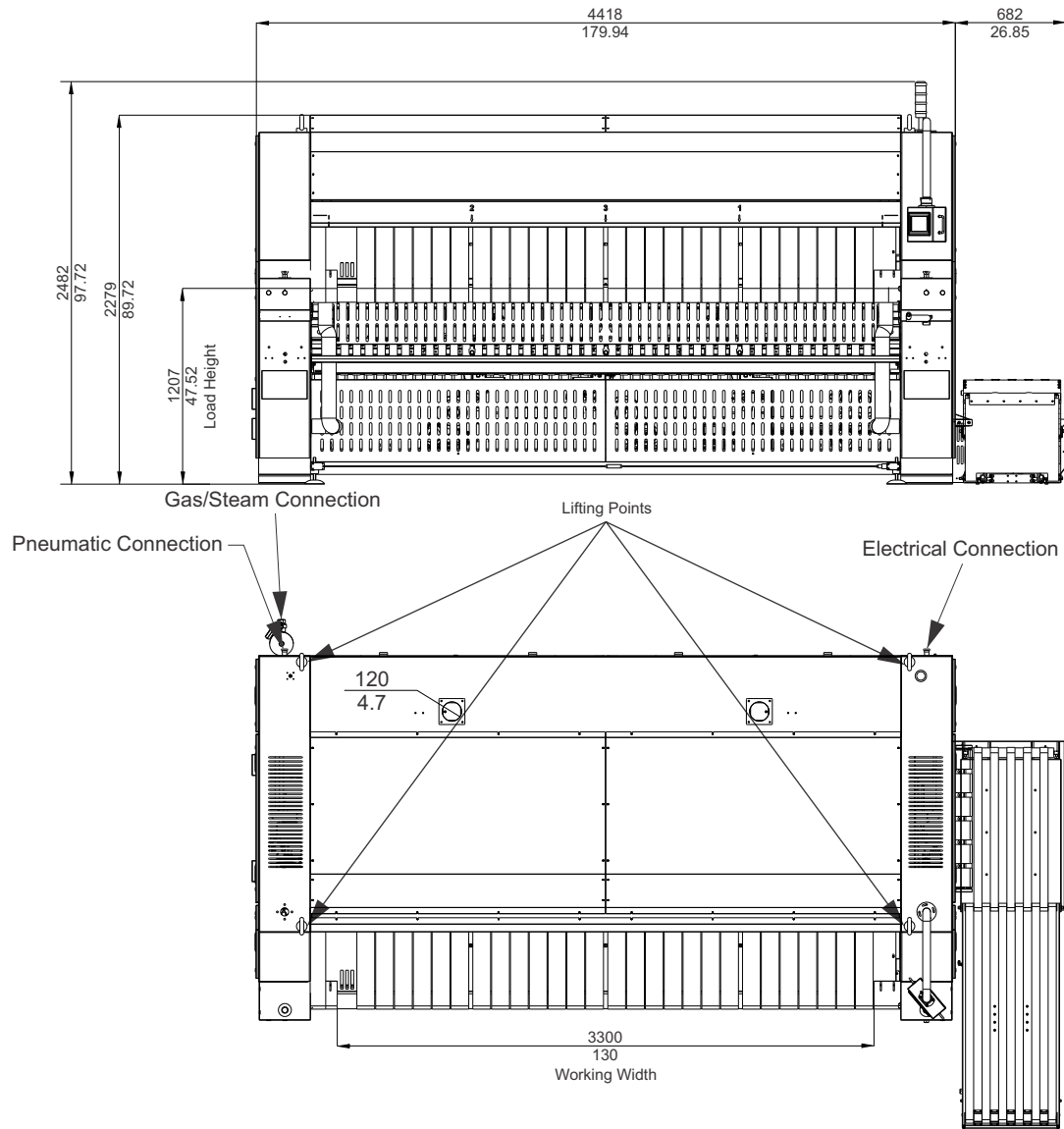

A

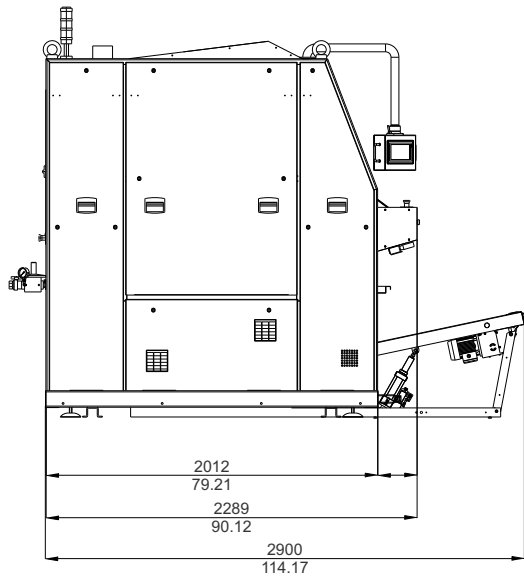

MODEL	Metric	US	IF-40130	
NUMBER OF ROLLS			1	
Roll Diameter	mm	inch	1000	40
Working Width	mm	inch	3300	130
DIMENSIONS				
A - Width (with stacker)	mm	inch	5060	199.2
B - Depth (with stacker)	mm	inch	2900	114.2
C - Height	mm	inch	2279	89.7
WEIGHT AND SHIPPING				
Net Weight	kg	lbs	4500	9900
Shipping Weight	kg	lbs	4700	10340
ELECTRICAL SERVICE:				
208-240VAC, 50/60Hz, 3PH	Amps	Breaker	31	40
380-480VAC, 50/60Hz, 3PH	Amps	Breaker	16	20
PNEUMATICS:				
Inlet	mm		12	
Consumption	L/h	cfm	24000	14.1
GAS:				
Heat Input	kCal/hr	BTU/hr	109560	434769
Gas Inlet	inch		1	
STEAM:				
Steam Consumption	kg/hr	BHP	185	11.9
Steam Inlet	inch		1	
Steam Return	inch		1/2	
EXHAUST				
Diameter (2 per machine)	mm	inch	120	4.7
Air Flow	cu m/hr	cfm	2000	1200

REV	BY	DATE	REV. DESCRIPTION
A2	AFA	7-19-2016	Updated dimensions
DRAWN BY		DATE	 Panama City Beach, FL Phone: 850-249-2222 Fax: 850-249-2226 www.bandtech.com
A. Adcock		9-16-2015	
CHECKED BY		DATE	
C. Oswald		9-16-2015	
DESCRIPTION			
General Technical Specifications IF-40130			
DATE	FILE NAME	SHEET	
9-16-2015	IF-40130-General.cdr	1 OF 1	